

ELECTROFUSION ELBOW 90° - HIGHER SIZE

For Gas/Water-SDR 11 (ISO S5)

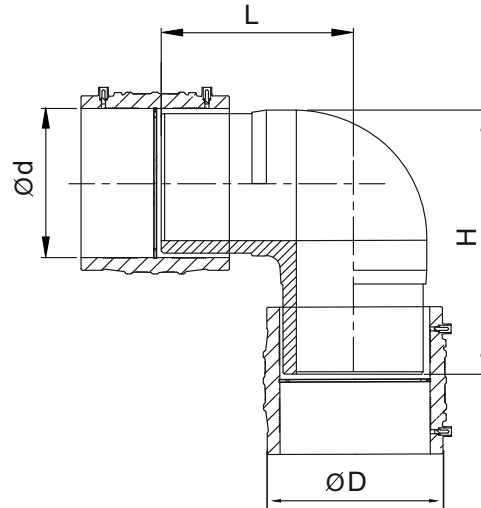

Kimplas Electrofusion Elbows Higher size are manufactured in PE 100 (Black) material and are of SDR 11 (PN 16) rated. They are suitable to weld SDR 9 through SDR 21 or PN 6 through PN 16 Pipes. Kimplas Electrofusion Elbows are suitable for permanently connecting MDPE 80 and PE 100 pipes, both in straight as well as in coil form.

SPECIFICATION TABLE

d	Product Code	SP	Weight (gm)	D(mm)	H (mm)	L (mm)	FT	CT
140	E140D90R11BKBSSET	3	4586	175	250	195	240	20
160	E160D90R11BKBSSET	3	6104	190	273	205	380	20
180	E180D90R11BKBSSET	3	8000	215	290	225	400	20
200	E200D90R11BKBSSET	2	10432	246	311	245	480	30
225	E225D90R11BKBSSET	2	14220	277	341	264	690	30
250	E250D90R11BKBSSET	2	19200	292	368	284	840	40
280	E280D90R11BKBSSET	2	27042	342	406	327	650	40
315	E315D90R11BKBSSET	2	36890	386	430	358	840	40

11BKBSSET - SDR 11 PE 100 Black - 4mm Pin

17BKBSSET - SDR 17 PE 100 Black - 4mm Pin

SP=Standard Pack Quantity, FT=Fusion Time in Seconds, CT=Cooling Time in Minutes, SP and Weight are given for reference only

Note: Every effort has been made to ensure the information in this brochure is correct at the date of issue. Kimplas operates a policy of continual product improvement and range extension, hence reserves the right to modify product specifications, without prior information, in line with market requirements.

STANDARDS

- Complies with EN 1555-Part 3, GIS-PL2-Part 4 for Gas, EN12201- Part 3 for Water.
- Complies with EN1555- Part 3 for Gas, EN12201- Part 3 for Water. AS/NZS 4129 for Gas & Water GIS-PL2-Part 4 for Gas

COMMON APPLICATIONS

- Make 90° turn on mains and distribution pipes in a distribution network.
- Turning pipe through 90° in narrow trenches, in areas difficult to access and House Service Connections.
- Pipe Connections with spigot end fittings, pipe stub ends etc.

INSTALLATION

Joint preparation must be done as specified in the installation instructions. Pipe outside surface must be scraped to remove oxidised layer. Before fusing, pipe ends and inside of the fittings must be cleaned to remove dirt and contamination. Complete Installation Manual may be downloaded.

ADVANTAGES

- Standard Operating Voltage - 40 V.
- Same fusion time for various SDR and PN rated pipes.
- Higher penetration of pipe in the fittings enables proper alignment.
- Optimal fusion and cold zone for a strong and sturdy joint.
- Auto Temperature compensation for ambient conditions -5°C to + 40°C.
- Clearance-Fit for ease of installation.
- Pop-Up fusion indicators to indicate fusion process performance.
- Permanent Batch Indicator, Fusion Time, Cooling Time, Raw Material Type and SDR marking.
- Each fitting individually packed in PE bag to protect against contamination and oxidation.
- Each fitting with water-proof bar code to automatically feed fusion data to the Control-box for fusion process.

Contact Us

Kimplas Piping Systems Private Limited - A member of NORMA Group -

B-20, MIDC , Ambad, Nashik- 422010 | India | www.kimplaspiping.net

Tel : +91 253 6622701/2 | Fax: +91 253 6604710 | Email: sales.kimplas@normagroup.com

