

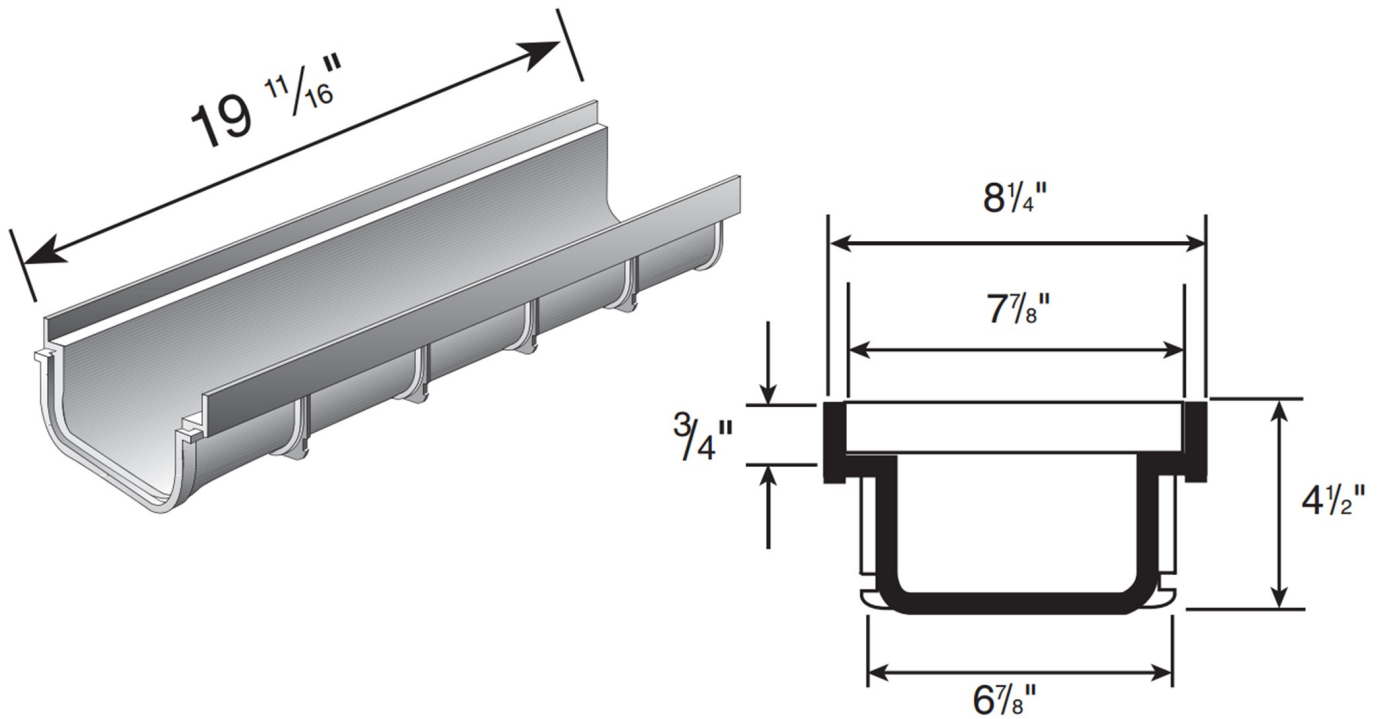

## TECHNICAL SPECIFICATION



PART NUMBER	SIZE	MATERIAL	WEIGHT
830	8-1/4" X 4-1/2" X 19-11/16"	HIGH IMPACT PVC	2.00 LBS

**SPECIFICATION:**

8" WIDE SHALLOW PROFILE CHANNEL DRAIN WITH MECHANICAL INTERLOCKING JOINTS.

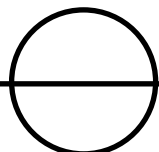

### 8" PRO SERIES CHANNEL DRAIN

SHALLOW PROFILE

FOR PRODUCT ASSISTANCE, CONTACT NDS TECHNICAL SERVICE AT [techservice@ndspro.com](mailto:techservice@ndspro.com), DESIGN ASSISTANCE- [designworx@ndspro.com](mailto:designworx@ndspro.com)  
 851 N. HARVARD AVE. LINDSAY, CA 93247 [WWW.NDSPRO.COM](http://WWW.NDSPRO.COM) 1-800-726-1994



## TECHNICAL SPECIFICATION

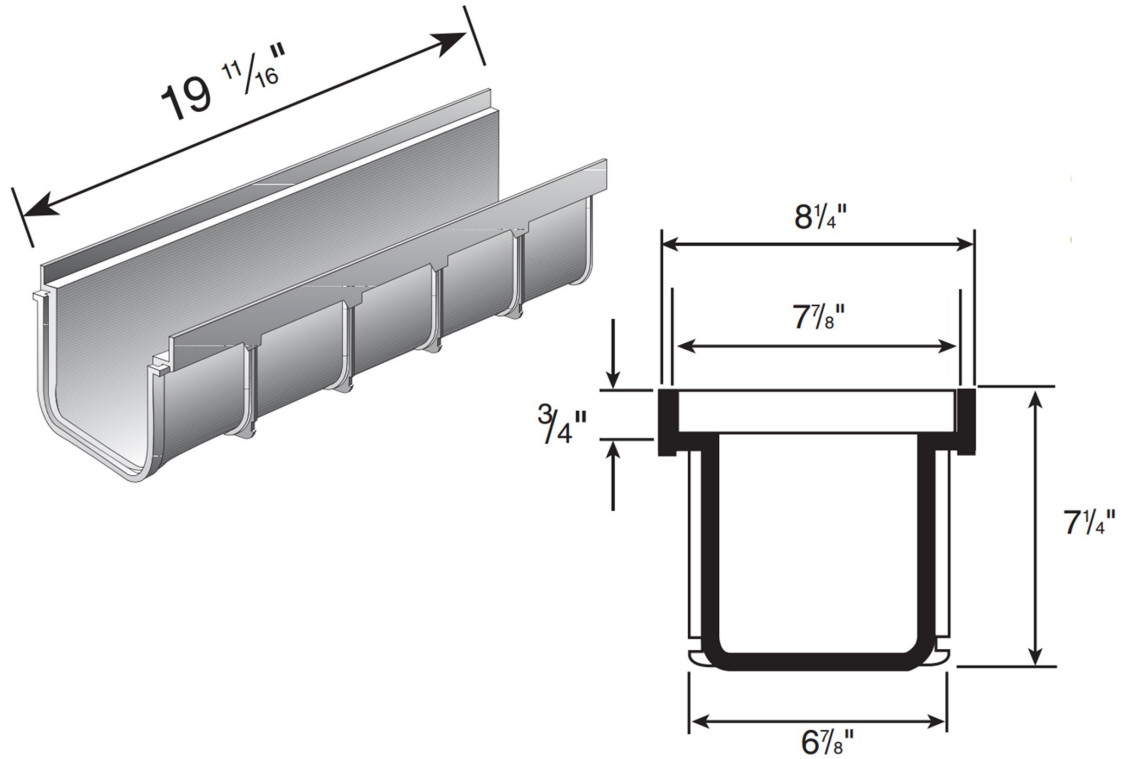

PART NUMBER	SIZE	MATERIAL	WEIGHT
833	8-1/4" X 7-1/4" X 19-11/16"	PVC WITH UV INHIBITORS	2.80 LBS

**SPECIFICATION:**  
 8" WIDE DEEP PROFILE CHANNEL DRAIN WITH MECHANICAL INTERLOCKING JOINTS.

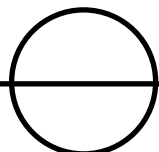

### 8" PRO SERIES CHANNEL DRAIN

DEEP PROFILE

FOR PRODUCT ASSISTANCE, CONTACT NDS TECHNICAL SERVICE AT [techservice@ndspro.com](mailto:techservice@ndspro.com), DESIGN ASSISTANCE- [designworx@ndspro.com](mailto:designworx@ndspro.com)  
 851 N. HARVARD AVE. LINDSAY, CA 93247 WWW.NDSPRO.COM 1-800-726-1994



## TECHNICAL SPECIFICATION

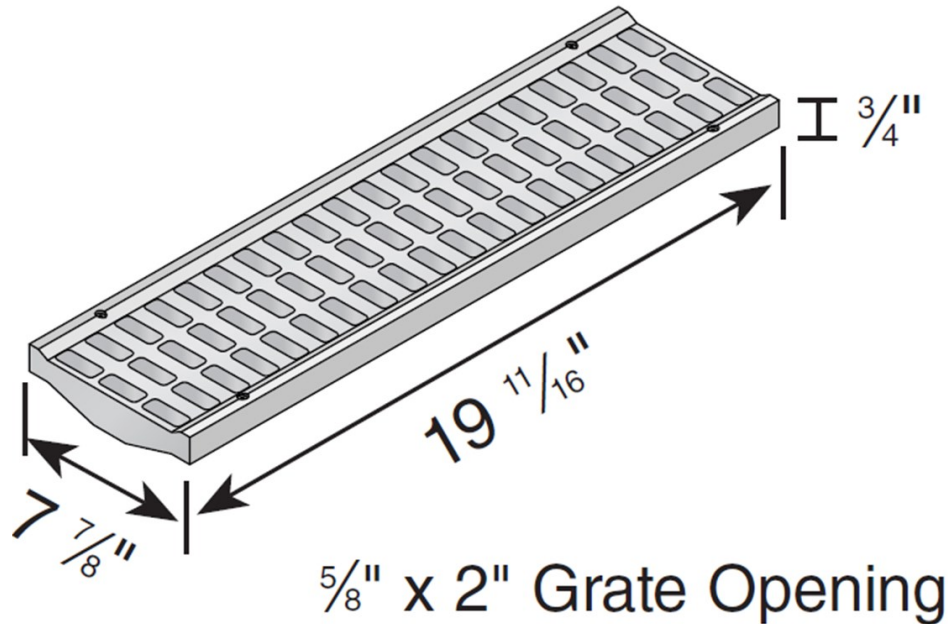

PART NUMBER	SIZE	GRATE OPENING	LOAD CLASS	OPEN AREA FLOW RATE W/ 1/2" HEAD	WEIGHT	ADA	HEEL PROOF
837	7-7/8" X 19-11/16" X 3/4"	5/8" X 2"	B	30.28 IN <sup>2</sup> 92.63GPM / LF	3 LBS	NO	NO

### SPECIFICATION:

MATERIAL: HDPE

LOAD CLASS B—LOADS OF 61-175 PSI. RECOMMENDED FOR MEDIUM-DUTY PNEUMATIC TIRE TRAFFIC, AUTOS AND LIGHT TRUCKS AT SPEEDS LESS THAN 20 MPH.

REQUIRES #829 (4) PER GRATE

FITS 8" PRO SERIES CHANNEL

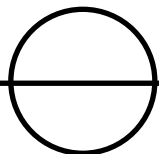

### 8" PRO SERIES GRATE

FOR PRODUCT ASSISTANCE, CONTACT NDS TECHNICAL SERVICE AT [techservice@ndspro.com](mailto:techservice@ndspro.com), DESIGN ASSISTANCE- [designworx@ndspro.com](mailto:designworx@ndspro.com)

851 N. HARVARD AVE. LINDSAY, CA 93247 WWW.NDSPRO.COM 1-800-726-1994



## TECHNICAL SPECIFICATION

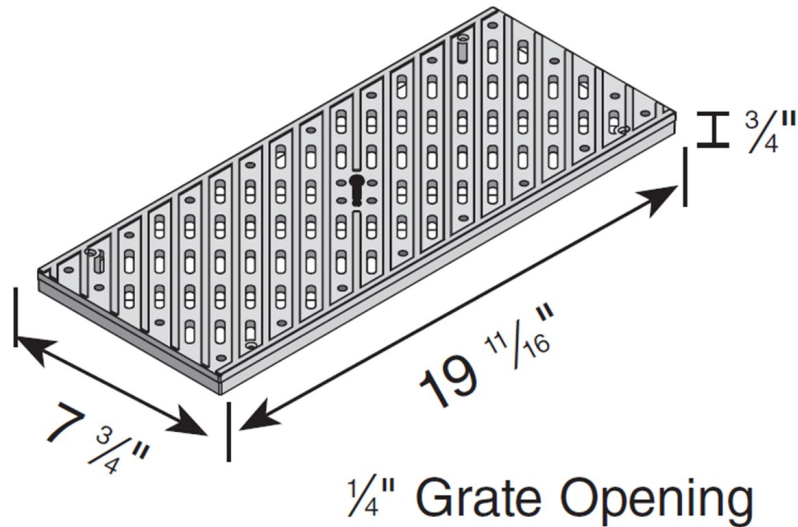

PART NUMBER	SIZE	GRATE OPENING	LOAD CLASS	OPEN AREA FLOW RATE W/ 1/2" HEAD	WEIGHT	ADA	HEEL PROOF
836	7-3/4" X 19-11/16" X 3/4"	1/4"	A	13.8 IN <sup>2</sup> 42 GPM / LF	1.6 LBS	YES	YES

### SPECIFICATION:

**MATERIAL:** HDPE

LOAD CLASS A—LOADS OF 1-60 PSI. RECOMMENDED FOR PEDESTRIANS, BICYCLES AND WHEEL CHAIR TRAFFIC

REQUIRES #829 (4) PER GRATE

FITS 8" PRO SERIES CHANNEL

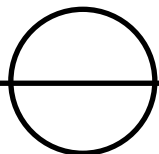

### 8" PRO SERIES GRATE

LOAD A, ADA/HEEL PROOF PEDESTRIAN RATED CHANNEL GRATE

FOR PRODUCT ASSISTANCE, CONTACT NDS TECHNICAL SERVICE AT [techservice@ndspro.com](mailto:techservice@ndspro.com), DESIGN ASSISTANCE- [designworx@ndspro.com](mailto:designworx@ndspro.com)

851 N. HARVARD AVE. LINDSAY, CA 93247 [WWW.NDSPRO.COM](http://WWW.NDSPRO.COM) 1-800-726-1994



## TECHNICAL SPECIFICATION

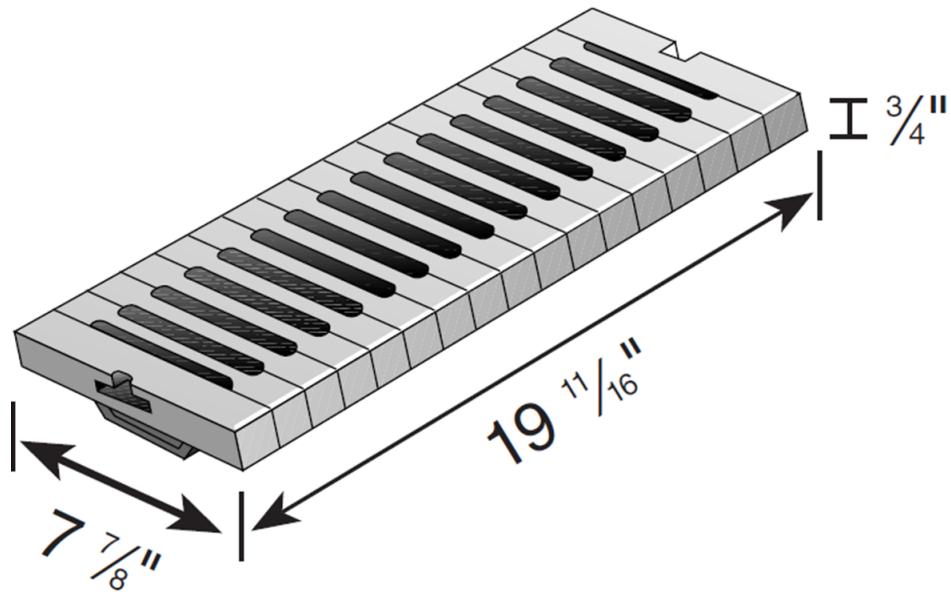

$\frac{1}{2}$ " x  $5 \frac{3}{4}$ " Grate Opening

PART NUMBER	SIZE	GRATE OPENING	LOAD CLASS	OPEN AREA FLOW RATE W/ 1/2" HEAD	WEIGHT	ADA	HEEL PROOF
838	7-7/8" X 19-11/16" X 3/4"	1/2" X 5-3/4"	C	30.9 IN <sup>2</sup> 95 GPM / LF	4 LBS	YES	NO

### **SPECIFICATION:**

MATERIAL: HIGH IMPACT GLASS REINFORCED NYLON

LOAD CLASS C—LOADS OF 176-325 PSI. RECOMMENDED FOR HEAVY-DUTY PNEUMATIC TIRE FORKLIFTS AND TRACTOR TRAILERS AT SPEEDS LESS THAN 20 MPH.

REQUIRES #829 (4) PER GRATE

FITS 8" PRO SERIES CHANNEL

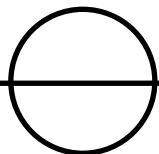

## 8" PRO SERIES GRATE

"LOAD STAR" HIGH IMPACT GLASS-REINFORCED NYLON

FOR PRODUCT ASSISTANCE, CONTACT NDS TECHNICAL SERVICE AT [techservice@ndspro.com](mailto:techservice@ndspro.com), DESIGN ASSISTANCE- [designworx@ndspro.com](mailto:designworx@ndspro.com)

851 N. HARVARD AVE. LINDSAY, CA 93247 [WWW.NDSPRO.COM](http://WWW.NDSPRO.COM) 1-800-726-1994



## TECHNICAL SPECIFICATION

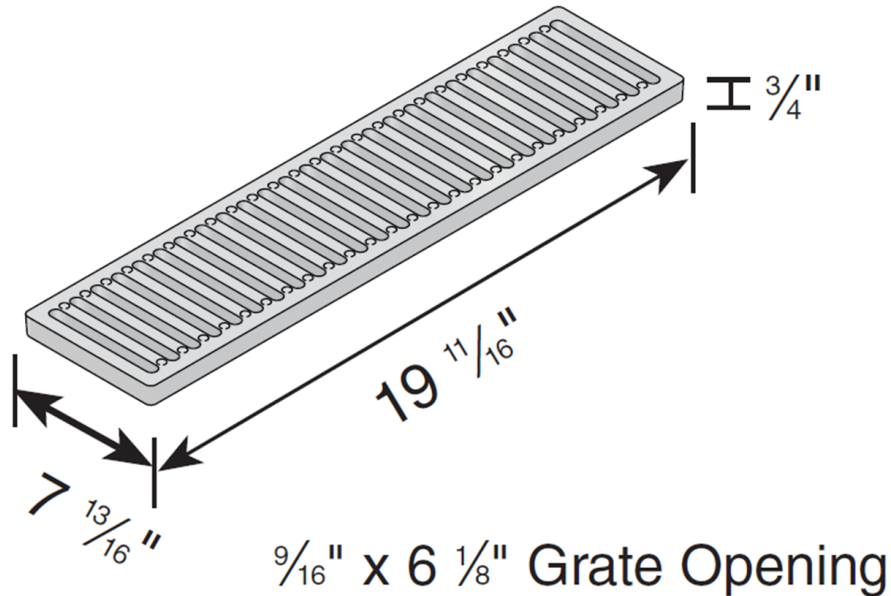

PART NUMBER	SIZE	SLOT WIDTH	LOAD CLASS	OPEN AREA FLOW RATE W/ 1/2" HEAD	WEIGHT	ADA	HEEL PROOF
888	7-13/16" X 19-11/16" X 3/4"	9/16" X 6-1/8"	C	23.31 <sup>2</sup> / LINEAR FOOT 71.28 GPM / LF	18.20 LBS	NO	NO

### **SPECIFICATION:**

MATERIAL: DUCTILE IRON

LOAD CLASS C— LOADS BETWEEN 176-325PSI, RECOMMENDED FOR HEAVY DUTY PNEUMATIC TIRE FORKLIFTS AND TRACTOR-TRAILERS AT SPEEDS LESS THAN 20 MPH. H-20 RATED.

REQUIRES #829 STAINLESS STEEL SCREWS (4 PER GRATE)

FITS 8" PRO SERIES CHANNEL

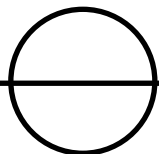

## 8" PRO SERIES GRATE

DUCTILE IRON - "SLOTTED", LOAD CLASS C

FOR PRODUCT ASSISTANCE, CONTACT NDS TECHNICAL SERVICE AT [techservice@ndspro.com](mailto:techservice@ndspro.com)  
851 N. HARVARD AVE. LINDSAY, CA 93247 WWW.NDSPRO.COM 1-800-726-1994