

Electrofusion Tee 32 mm for Gas Application

Technical Data Sheet



Overview:

The 3-side Electrofusion Tee is a compact and optimized pipe fitting suitable for HDPE Gas pipeline systems. It integrates multiple functionalities to reduce installation complexity and optimize system layout.

Key Features:

- ✓ **Integrated Tee Design:** Eliminates the need for an additional coupler on the spigot side.
- ✓ **Time Efficient Installation:** Pre-fused assembly reduces jointing and labour costs.
- ✓ **Optimised Spigot Length:** Shorter installation footprint.
- ✓ **Inventory Efficiency:** Multi-functionality reduces SKU count and storage space.
- ✓ **Compact Construction:** Engineered for space-constrained environments.

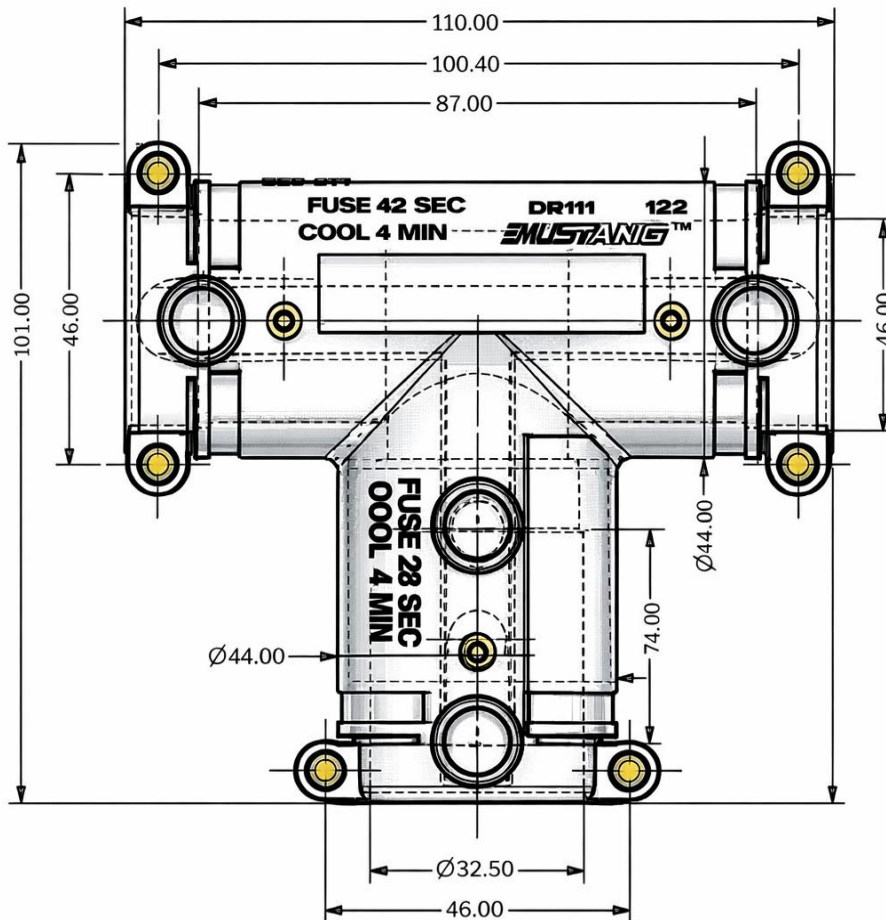

Parameter	Description
Product Type	3-Side Electrofusion Tee
Material	PE100(Polyethylene)
Product Code	EBSTEE32BKD
Size	D32 x D32 x D32(Main x branch)
Standard Dimension Ratio (SDR)	SDR11
Fusion Time	42 seconds (FUSE 42 S), 28 seconds (FUSE 28 S)
Cooling Time	7 minutes (COOL 7 M), 4 minutes (COOL 4M)
Pressure Rating	PN16(based on SDR11)
Compliance Standards	EN 1555-3
Colour	Black
Marking	Brand – TRUSTLENE, size, SDR, Fusion/Cooling details



Fig.1 D32 EQUAL TEE WITH PIPE

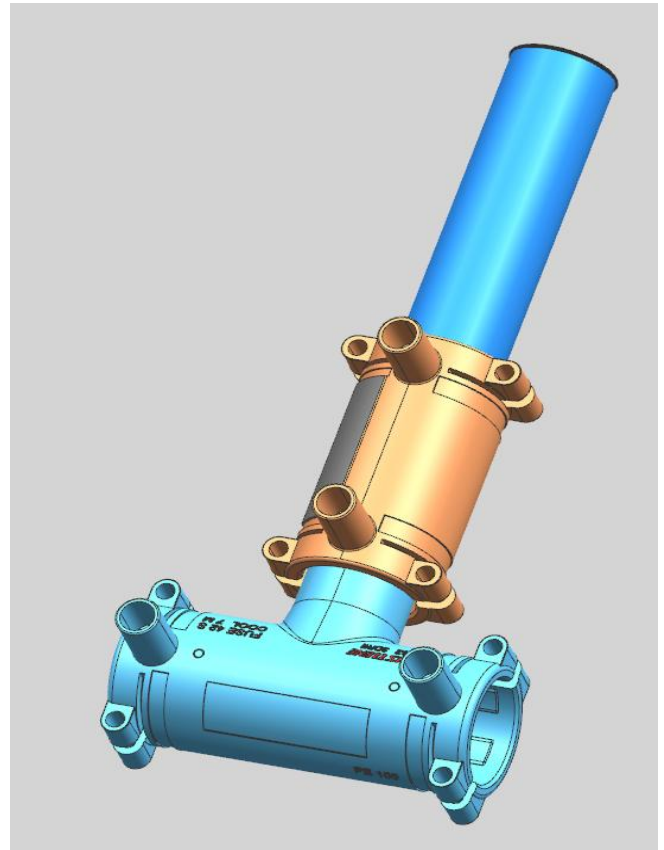





Fig.2 D32 EQUAL TEE WITH D32 COUPLER

Advantages:

-  **Reduced Parts:** Combines functions of multiple fittings.
-  **Faster Installation:** Less time on-site.
-  **Lower Inventory:** Fewer Part numbers needed.
-  **Compact Footprint:** Easier to install in tight spaces.

****Suitable for PE100 & PE80 pipes.

TRUSTLENE Brand Pipes & Fittings

Kimplas Piping Systems Pvt. Ltd.

B-20, MIDC Ambad, Nashik – 422010, Maharashtra, India

www.kimplaspiping.net