

EF IC METAL (BRASS) TRANSITION COUPLER

DxD	Threads	Product Code	SP	Wt. (gm)	D1 (mm)	L (mm)	FT (secs)	CT (mins)
20x1/2"	NPT	MTC20X050NPTBRBKD	100	106	31	78	19	4
20x1/2"	BSP	MTC20X050BSPBRBKD	100	106	31	78	19	4

BKD – PE 100 Black 4mm Pin

WELDABLE TRANSITION FITTING(STEEL-PE)

(Carbon Steel pipe with zinc coated x PE 100 SDR11 Pipe)

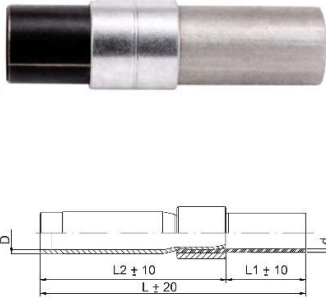

dxD	Product Code	Wt. (gm)	L (mm)	L1 (mm)	L2 (mm)
32mmx1"	WTFPEGID32X100BKL	1.2	400	100	300
40mmx1 1/4"	WTFPEGID40X125BKL	1.7	460	160	300
50mmx1 1/2"	WTFPEGID50X150BKL	1.8	460	160	300
63mmx2"	WTFPEGID63X200BKL	2.7	485	185	300
90mmx3"	WTFPEGID90X300BKL	6.2	510	190	320
100mmx4"	WTFPEGID100X400BKL	10.1	510	190	320
125mmx4"	WTFPEGID125X400BKL	10.5	510	190	320
160mmx6"	WTFPEGID160X600BKL	18.3	630	200	430
180mmx6"	WTFPEGID180X600BKL	18.7	630	200	430

Carbon Steel – API 5L
PE 100 SDR11 Pipe as per ISO 4437

BRASS SPIGOT TRANSITION FITTING–MALE BSPT



dxD	Product Code	Wt. (gm)	L (mm)	L1 (mm)	L2 (mm)
d20x1/2"	BSPTRA20X050MBSPT	50	118	97	43
d20x3/4"	BSPTRA20X075MBSPT	50	127	97	43
d25x3/4"	BSPTRA25X075MBSPT	50	147	97	43
d32x3/4"	BSPTRA32X075MBSPT	60	201	103	43
d32x1"	BSPTRA32X100MBSPT	50	233	103	43
d40x1.1/4"	BSPTRA40X125MBSPT	45	374	126	53
d50x1.1/2"	BSPTRA50X150MBSPT	40	437	133	61
d63x2"	BSPTRA63X200MBSPT	25	698	139	43

MBSPT – PE 100 Black - BSPT
MNPT – PE 100 Black - NPT

BRASS SPIGOT TRANSITION FITTING–FEMALE BSP



dxD	Product Code	Wt. (gm)	L (mm)	L1 (mm)	L2 (mm)
d20 x 1/2"	BSPTRAN20X050FBSP	50	94	81	43
d25 x 3/4"	BSPTRAN25X075FBSP	50	116	81	43
d32 x 3/4"	BSPTRAN32X075FBSP	50	163	83	43
d32 x 1"	BSPTRAN32X100FBSP	50	171	83	43
d40 x 1.1/4"	BSPTRAN40X125FBSP	45	310	104	53
d50 x 1.1/2"	BSPTRAN50X150FBSP	40	365	111	61
d63 x 2"	BSPTRAN63X200FBSP	25	541	115	63
d20 x 1/2"	BSPTRAN20X050FBSP	50	94	81	43

FBSP – PE 100 Black - BSP
FNPT – PE 100 Black - NPT

EF BRASS TRANSITION COUPLER - MALE



dxD	Product Code	SP	Wt. (gm)	L (mm)	L1 (mm)	L2 (mm)	L3 (mm)	FT	CT
d20x1/2"	TCB20X050MBSPTBKD	-	171	137	97	60	38	22	4
d20x3/4"	TCB20X075MBSPTBKD	-	180	137	97	60	38	22	4
d25x3/4"	TCB25X075MBSPTBKD	-	210	138	97	59	39	28	4
d32x3/4"	TCB32X075MBSPTBKD	-	276	124	83	60	41	42	4
d32x1"	TCB32X100MBSPTBKD	-	308	145	103	63	40	42	4
d40x1.1/4"	TCB40X125MBSPTBKD	-	470	167	126	73	42	52	7
d50x1.1/2"	TCB50X150MBSPTBKD	-	578	185	133	72	53	55	7
d63x2"	TCB63X200MBSPTBKD	-	918	190	139	90	49	70	7

MBSPTBKD – PE 100 Black – BSPT – 4mm Pin
 MNPTBKD – PE 100 Black – NPT – 4mm Pin

EF BRASS TRANSITION COUPLER-FEMALE



dxD	Product Code	SP	Wt. (gm)	L (mm)	L1 (mm)	L2 (mm)	L3 (mm)	FT	CT
d20x1/2"	TCB20X050FBSPBKD	-	147	121	81	38	38	22	4
d25x3/4"	TCB25X075FBSPBKD	-	179	122	81	38	39	28	4
d32x3/4"	TCB32X075FBSPBKD	-	351	124	83	40	41	42	4
d32x1"	TCB32X100FBSPBKD	-	246	125	83	43	40	42	4
d40x1.1/4"	TCB40X125FBSPBKD	-	406	146	104	51	42	52	7
d50x1.1/2"	TCB50X150FBSPBKD	-	506	164	111	50	53	55	7
d63x2"	TCB63X200FBSPBKD	-	761	166	115	52	49	70	7

FBSPBKD – PE 100 Black – BSP – 4mm Pin
 FNPTBKD – PE 100 Black – NPT – 4mm Pin

EF BRASS TRANSITION ELBOW - 90° MALE

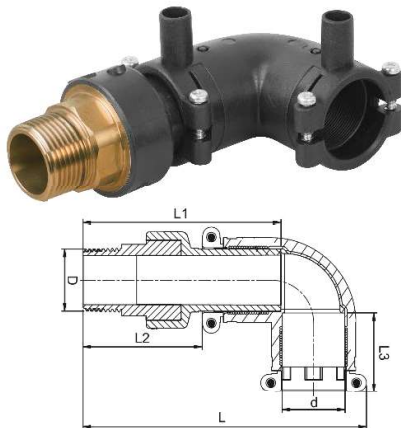

dxD	Product Code	SP	Wt. (gm)	L (mm)	L1 (mm)	L2 (mm)	L3 (mm)	FT	CT
d20x1/2"	TE9B20X050MBSPTBKD	-	181	136	97	60	38	22	4
d20x3/4"	TE9B20X075MBSPTBKD	-	190	136	97	60	38	22	4
d32x3/4"	TE9B32X075MBSPTBKD	-	291	149	103	63	43	42	4
d32x1"	TE9B32X100MBSPTBKD	-	323	149	103	63	40	42	4
d40x1.1/4"	TE9B40X125MBSPTBKD	-	515	176	126	72	51	52	7
d50x1.1/2"	TE9B50X150MBSPTBKD	-	572	190	133	71	58	55	7
D63x2"	TE9B63X200MBSPTBKD	-	1013	220	139	90	49	70	7

MBSPTBKD – PE 100 Black – BSPT – 4mm Pin
 MNPTBKD – PE 100 Black – NPT – 4mm Pin

EF BRASS TRANSITION ELBOW - 90° FEMALE

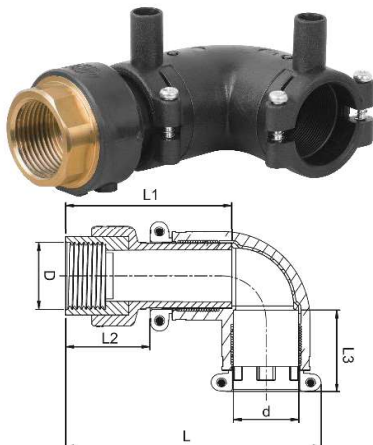

dxD	Product Code	SP	Wt. (gm)	L (mm)	L1 (mm)	L2 (mm)	L3 (mm)	FT	CT
d20x1/2"	TE9B20X050FBSPBKD	-	157	120	81	38	38	22	4
d25x3/4"	TE9B25X075FBSPBKD	-	186	121	81	38	39	28	4
d32x1"	TE9B32X100FBSPBKD	-	261	126	83	43	40	42	4
d40x1.1/4"	TE9B40X125FBSPBKD	-	451	155	104	51	51	52	7
d50x1.1/2"	TE9B50X150FBSPBKD	-	500	169	111	50	58	55	7
d63x2"	TE9B63X200FBSPBKD	-	856	196	115	66	49	70	7

FBSPBKD – PE 100 Black – BSP – 4mm Pin
 FNPTBKD – PE 100 Black – NPT – 4mm Pin

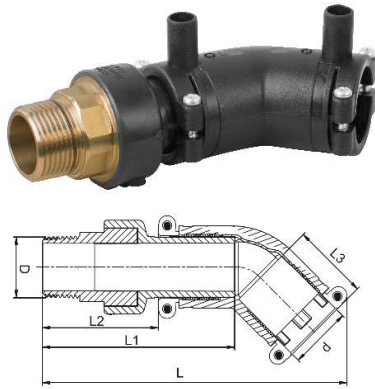

EF RASS TRANSITION ELBOW - 45° MALE

dxD	Product Code	SP	Wt. (gm)	L (mm)	L1 (mm)	L2 (mm)	L3 (mm)	FT	CT
d20x1/2"	TE4B20X050MBSPTBKD	-	173	147	97	60	43	22	4
d20x3/4"	TE4B20X075MBSPTBKD	-	182	147	97	60	43	22	4
d25x3/4"	TE4B25X075MBSPTBKD	-	219	155	97	59	48	28	4
d32x3/4"	TE4B32X075MBSPTBKD	-	286	164	103	63	51	42	4
d32x1"	TE4B32X100MBSPTBKD	-	318	164	103	63	40	42	4
d40x1.1/4"	TE4B40X125MBSPTBKD	-	499	184	126	73	58	52	7
d50x1.1/2"	TE4B50X150MBSPTBKD	-	618	197	133	72	65	55	7
d63x2"	TE4B63X200MBSPTBKD	-	1001	215	139	90	77	70	7

MBSPTBKD – PE 100 Black – BSPT – 4mm Pin
 MNPTBKD – PE 100 Black – NPT – 4mm Pin

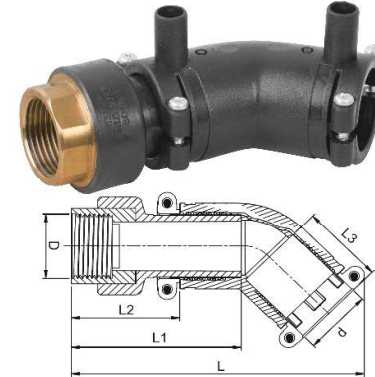

EF BRASS TRANSITION ELBOW - 45° FEMALE

dxD	Product Code	SP	Wt. (gm)	L (mm)	L1 (mm)	L2 (mm)	L3 (mm)	FT	CT
d20x1/2"	TE4B20X050FBSPBKD	-	149	131	81	38	43	22	4
d25x3/4"	TE4B25X075FBSPBKD	-	188	139	81	38	43	28	4
d32x3/4"	TE4B32X075FBSPBKD	-	248	144	83	40	50	42	4
d32x1"	TE4B32X100FBSPBKD	-	256	144	83	43	40	42	4
d40x1.1/4"	TE4B40X125FBSPBKD	-	435	162	104	51	58	52	7
d50x1.1/2"	TE4B50X150FBSPBKD	-	546	176	111	50	65	55	7
d63x2"	TE4B63X200FBSPBKD	-	844	191	115	52	76	70	7

FBSPBKD – PE 100 Black – BSP – 4mm Pin
 FNPTBKD – PE 100 Black – NPT – 4mm Pin



EF BRASS TRANSITION REDUCER – MALE

dxD	Product Code	SP	Wt. (gm)	L (mm)	FT	CT
32 x 1/2"	TRED32X050MBSPTBKD	-	193	143	34	4
32 x 3/4"	TRED32X075MBSPTBKD	-	222	143	30	4
40 x 1/2"	TRED40X050MBSPTBKD	-	206	154	30	7
40 x 3/4"	TRED40X075MBSPTBKD	-	239	154	30	7
40 x 1"	TRED40X100MBSPTBKD	-	298	208	42	7
50 x 3/4"	TRED50X075MBSPTBKD	-	250	203	30	7
50 x 1"	TRED50X100MBSPTBKD	-	342	170	36	7
50 x 1 1/4"	TRED50X125MBSPTBKD	-	492	183	46	7
63 x 1"	TRED63X100MBSPTBKD	-	406	166	47	7
63 x 1 1/4"	TRED63X125MBSPTBKD	-	561	192	42	7
63 x 1 1/2"	TRED63X150MBSPTBKD	-	642	192	45	7

MBSPTBKD – PE 100 Black – BSPT – 4mm Pin
 MNPTBKD – PE 100 Black – NPT – 4mm Pin

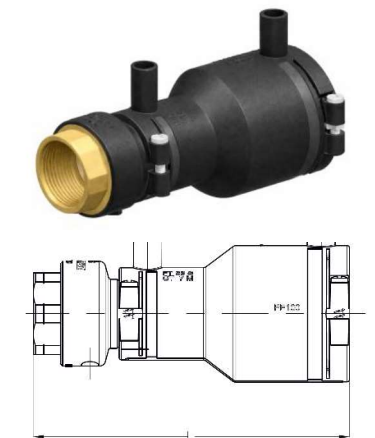

EF BRASS TRANSITION REDUCER - FEMALE

dxD	Product Code	SP	Wt. (gm)	L (mm)	FT	CT
32 x 1/2"	TRED32X050FBSPBKD	-	169	127	34	4
32 x 3/4"	TRED32X075FBSPBKD	-	191	127	30	4
40 x 1/2"	TRED40X050FBSPBKD	-	182	138	30	7
40 x 3/4"	TRED40X075FBSPBKD	-	208	138	30	7
40 x 1"	TRED40X100FBSPBKD	-	268	137	42	7
50 x 3/4"	TRED50X075FBSPBKD	-	219	138	30	7
50 x 1"	TRED50X100FBSPBKD	-	280	153	36	7
50 x 1 1/4"	TRED50X125FBSPBKD	-	428	161	46	7
63 x 1"	TRED63X100FBSPBKD	-	344	149	47	7
63 x 1 1/4"	TRED63X125FBSPBKD	-	497	170	42	7
63 x 1 1/2"	TRED63X150FBSPBKD	-	570	170	45	7

FBSPBKD – PE 100 Black – BSP – 4mm Pin
 FNPTBKD – PE 100 Black – NPT – 4mm Pin