

ELECTROFUSION ELBOW 90°

For Gas/Water-SDR 11 (ISO S5)

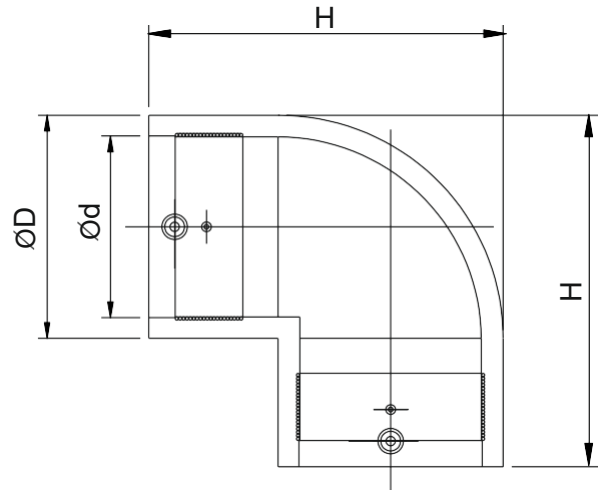

Kimplas Electrofusion Elbows are manufactured in PE 80 (Yellow) and PE 100 (Black) material and are of **SDR 11** rating. For exact recommendations on compatibility for welding with SDR 9 through SDR 21, refer Kimplas Technical Manual. Kimplas Electrofusion Reducers are suitable for permanently connecting PE 80 pipes and PE 100 pipes, both in straight as well as in coil form.

SPECIFICATION TABLE

d	Product Code	SP	Weight (gm)	D(mm)	H (mm)	FT	CT
20	E20D90BKB	168	35	33	70	22	4
25	E25D90BKB	120	35	35	71	28	4
32	E32D90BKB	100	48	44	75	42	4
40	E40D90BKB	60	117	53	92	52	7
63	E63D90BKB	21	290	82	122	70	7
75	E75D90BKB	15	401	94	137	80	7
90	E90D90BKB	8	655	113	172	140	15
110	E110D90BKB	4	806	137	209	160	15
125	E125D90BKB	4	1529	155	230	200	15

BKB - PE 100 Black - 4mm Pin
BKA - PE 100 Black - 4.7mm Pin

BK8A - PE 80 Black - 4.7mm Pin
BK8B - PE 80 Black - 4mm Pin

YEA - PE 80 Yellow - 4.7mm Pin

SP=Standard Pack Quantity, FT=Fusion Time in Seconds, CT=Cooling Time in Minutes, SP and Weight are given for reference only

Note: Every effort has been made to ensure the information in this brochure is correct at the date of issue. Kimplas operates a policy of continual product improvement and range extension, hence reserves the right to modify product specifications, without prior information, in line with market requirements.

STANDARDS

- Complies with EN 1555-Part 3, GIS-PL2-Part 4 for Gas, EN12201- Part 3 for Water.
- Complies with EN1555- Part 3 for Gas, EN12201- Part 3 for Water. AS/NZS 4129 for Gas & Water GIS-PL2-Part 4 for Gas

COMMON APPLICATIONS

- Make 90° turn on mains and distribution pipes in a distribution network.
- Turning pipe through 90° in narrow trenches, in areas difficult to access and House Service Connections.
- Pipe Connections with spigot end fittings, pipe stub ends etc.

INSTALLATION

Joint preparation must be done as specified in the installation instructions. Pipe outside surface must be scraped to remove oxidised layer. Before fusing, pipe ends and inside of the fittings must be cleaned to remove dirt and contamination. Complete Installation Manual may be downloaded.

ADVANTAGES

- Standard Operating Voltage - 40 V.
- Same fusion time for various SDR and PN rated pipes.
- Higher penetration of pipe in the fittings enables proper alignment.
- Optimal fusion and cold zone for a strong and sturdy joint.
- Auto Temperature compensation for ambient conditions -5°C to + 40°C.
- Clearance-Fit for ease of installation.
- Pop-Up fusion indicators to indicate fusion process performance.
- Permanent Batch Indicator, Fusion Time, Cooling Time, Raw Material Type and SDR marking.
- Each fitting individually packed in PE bag to protect against contamination and oxidation.
- Each fitting with water-proof bar code to automatically feed fusion data to the Control-box for fusion process.

Contact Us

Kimplas Piping Systems Private Limited

B-20, MIDC , Ambad, Nashik- 422010 | India | www.kimplaspiping.net

