

ELECTROFUSION END CAP

For Gas/Water-SDR 11 (ISO S5)

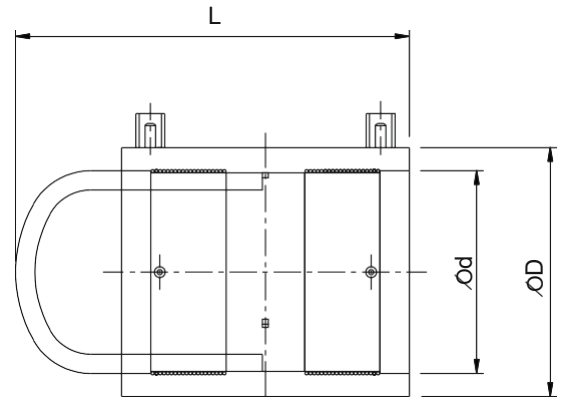

Kimplas Electrofusion End Caps consist of Standard Electrofusion Coupler and a Spigot End Cap and are manufactured in PE 80 Yellow and PE 100 Black material and are of SDR 11 rating. For exact recommendations on compatibility, for welding with SDR 9 through SDR 21 or PN 6 through PN 16 pipe, refer Kimplas Technical Specifications Manual. Kimplas Electrofusion fittings are suitable for permanently connecting to PE 80 and PE 100 pipes, both in straight as well as in coil form.

SPECIFICATION TABLE

d	Product Code	SP	Weight (gm)	D(mm)	L (mm)	FT	CT
20	ECSC20BKB	160	54	31	99	22	4
25	ECSC25BKB	120	67	37	100	28	4
32	ECSC32BKB	100	88	45	105	42	4
40	ECSC40BKB	75	105	53	115	52	7
50	ECSC50BKB	36	218	65	138	55	7
55	ECSC55BKB	40	218	69	138	40	7
63	ECSC63BKB	24	327	81	150	70	7
75	ECSC75BKB	18	397	91	168	80	7
90	ECSC90BKB	10	782	113	193	140	15
110	ECSC110BKB	8	1254	138	217	160	15
125	ECSC125BKB	6	1760	155	130	200	15
125	ECSC125BKBF	6	1495	152	130	220	15
140	ECSC140BKN	6	2000	175	264	240	20

BKN - PE 100 Black - 4mm Pin
BKA - PE 100 Black - 4.7mm Pin

BK8A - PE 80 Black - 4.7mm Pin
BK8B - PE 80 Black - 4mm Pin

YEA - PE 80 Yellow - 4.7mm Pin

SP=Standard Pack Quantity, FT=Fusion Time in Seconds, CT=Cooling Time in Minutes, SP and Weight are given for reference only

Note: Every effort has been made to ensure the information in this brochure is correct at the date of issue. Kimplas operates a policy of continual product improvement and range extension, hence reserves the right to modify product specifications, without prior information, in line with market requirements.

EF END CAP - HIGHER SIZES

For Gas/Water-SDR 11 (ISO S5)

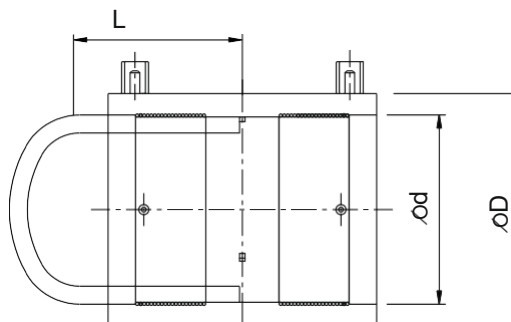

Kimplas Electrofusion End Caps consist of Standard Electrofusion Coupler and a Spigot End Cap and are manufactured in PE 100 Black material and are of SDR 11 rating. For exact recommendations on compatibility, for welding with SDR 9 through SDR 21 or PN 6 through PN 16 pipe, refer Kimplas Technical Specifications Manual. Kimplas Electrofusion fittings are suitable for permanently connecting to PE 80 and PE 100 pipes, both in straight as well as in coil form.

SPECIFICATION TABLE

d	Product Code	SP	Weight (gm)	D(mm)	L (mm)	FT	CT
160	ECSC160R11BKBSET	4	2607	190	98	380	20
180	ECSC180R11BKBSET	3	3416	215	105	400	20
200	ECSC200R11BKBSET	3	4158	246	112	480	30
225	ECSC225R11BKBSET	3	6020	277	120	690	30
250	ECSC250R11BKBSET	2	7740	292	129	840	40
280	ECSC280R11BKBSET	2	10380	342	139	650	40
315	ECSC315R11BKBSET	2	14340	386	150	840	40

11BKBSET - SDR 11 PE 100 Black - 4mm Pin

17BKBSET - SDR 17 PE 100 Black - 4mm Pin

SP=Standard Pack Quantity, FT=Fusion Time in Seconds, CT=Cooling Time in Minutes, SP and Weight are given for reference only

Note: Every effort has been made to ensure the information in this brochure is correct at the date of issue. Kimplas operates a policy of continual product improvement and range extension, hence reserves the right to modify product specifications, without prior information, in line with market requirements.

STANDARDS

- PE Pipe Compatibility : IS:14885, ISO:4437, EN:1555-2, EN: 12201-2, ISO:4427, IS: 4984, DIN:8074.
- Complies with EN1555- Part 3 for Gas, EN12201- Part 3 for Water. AS/NZS 4129 for Gas & Water GIS-PL2-Part 4 for Gas

COMMON APPLICATIONS

- Closing ends of pipe permanently on mains and distribution pipes in a distribution network.
- Closing spigot end of fittings.

INSTALLATION

Joint preparation must be done as specified in the installation instructions. Pipe outside surface must be scraped to remove oxidized layer. Before fusing, pipe ends and inside of the fittings must be cleaned to remove dirt and contamination. Complete Installation Manual may be downloaded.

ADVANTAGES

- Standard Operating Voltage - 40 V.
- Same fusion time for fusion with various SDR & PN rated pipes.
- Higher penetration of pipe in the fittings enables proper alignment.
- Optimal fusion and cold zone for a strong and sturdy joint.
- Auto Temperature compensation for ambient conditions -5°C to + 40°C.
- Clearance-Fit for ease of installation.
- Pop-Up fusion indicators to indicate fusion process performance.
- Permanent Batch Indicator, Fusion Time, Cooling Time, Raw Material Type and SDR marking.
- Each fitting individually packed in PE bag to protect against contamination and oxidation.
- Each fitting with water-proof bar code to automatically feed fusion data to the Control-box for fusion process.

Contact Us

Kimplas Piping Systems Private Limited

B-20, MIDC , Ambad, Nashik- 422010 | India | www.kimplaspiping.net

