

ELECTROFUSION EQUAL TEE - HIGHER SIZE

For Gas/Water-SDR 11 (ISO S5)

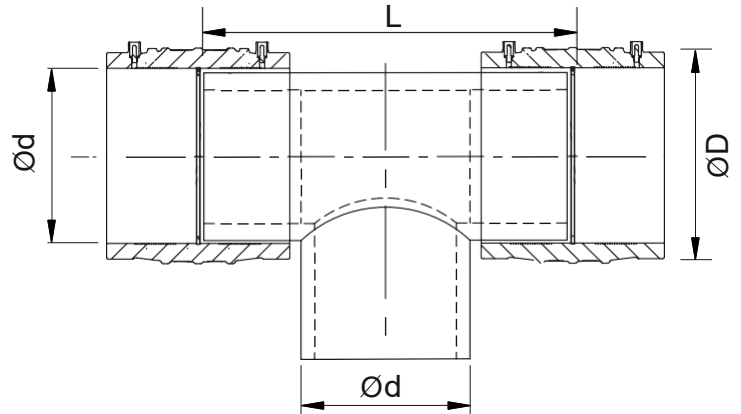

Kimplas Electrofusion Equal Tee are manufactured in PE 100 (Black) material and are of SDR 11 rating (PN 6). For exact recommendations on compatibility, for welding with SDR 9 through SDR 21 or PN 6 through PN 16 pipe, refer Kimplas Technical Specifications Manual. Kimplas Electrofusion fittings are suitable for permanently connecting PE80 and PE100 pipes, both in straight as well as in coil form.

SPECIFICATION TABLE

d	Product Code	SP	Weight (gm)	D (mm)	L (mm)	FT	CT
140	ET140R11BKSET	2	5185	175	380	240	20
160	ET160R11BKSET	2	7300	190	417	380	20
180	ET180R11BKSET	2	9658	215	458	400	20
200	ET200R11BKSET	2	12030	246	481	480	30
225	ET225R11BKSET	2	17126	277	527	690	30
250	ET250R11BKSET	2	22768	292	590	840	40
280	ET280R11BKSET	2	33164	342	690	650	40
315	ET315R11BKSET	2	43126	386	712	840	40

11BKSET - SDR 11 PE 100 Black - 4mm Pin

17BKSET - SDR 17 PE 100 Black - 4mm Pin

SP=Standard Pack Quantity, FT=Fusion Time in Seconds, CT=Cooling Time in Minutes, SP and Weight are given for reference only

Note: Every effort has been made to ensure the information in this brochure is correct at the date of issue. Kimplas operates a policy of continual product improvement and range extension, hence reserves the right to modify product specifications, without prior information, in line with market requirements.

STANDARDS

- PE Pipe Compatibility : IS:14885,ISO 4437-Part 2, EN:1555-2, EN: 12201-2, ISO:4427, IS: 4984, DIN:8074. for Gas / Water - SDR11 (ISO S5)
- Complies with EN1555- Part 3 for Gas, EN12201- Part 3 for Water. AS/NZS 4129 for Gas & Water GIS-PL2-Part 4 for Gas

COMMON APPLICATIONS

- Make a branch connection on mains and distribution pipes in a distribution network.
- Taking branch connections in narrow trenches, in areas difficult to access and House Service Connections.
- Pipe Connections with spigot end fittings, pipe stub ends etc.

INSTALLATION

Joint preparation must be done as specified in the installation instructions. Pipe outside surface must be scraped to remove oxidized layer. Before fusing, pipe ends and inside of the fittings must be cleaned to remove dirt and contamination. Complete Installation Manual may be downloaded.

ADVANTAGES

- Standard Operating Voltage - 40 V.
- Same fusion time for various SDR and PN rated pipes.
- Higher penetration of pipe in the fittings enables proper alignment.
- Optimal fusion and cold zone for a strong and sturdy joint.
- Auto Temperature compensation for ambient conditions -5°C to + 40°C.
- Clearance-Fit for ease of installation.
- Pop-Up fusion indicators to indicate fusion process performance.
- Permanent Batch Indicator, Fusion Time, Cooling Time, Raw Material Type and SDR marking.
- Each fitting individually packed in PE bag to protect against contamination and oxidation.
- Each fitting with water-proof bar code to automatically feed fusion data to the Control-box for fusion process.

Contact Us

Kimplas Piping Systems Private Limited

B-20, MIDC , Ambad, Nashik- 422010 | India | www.kimplaspiping.net

