

## ELECTROFUSION FLEXI - FIT TAPPING TEE

For Gas/Water-SDR 11 (ISO S5)

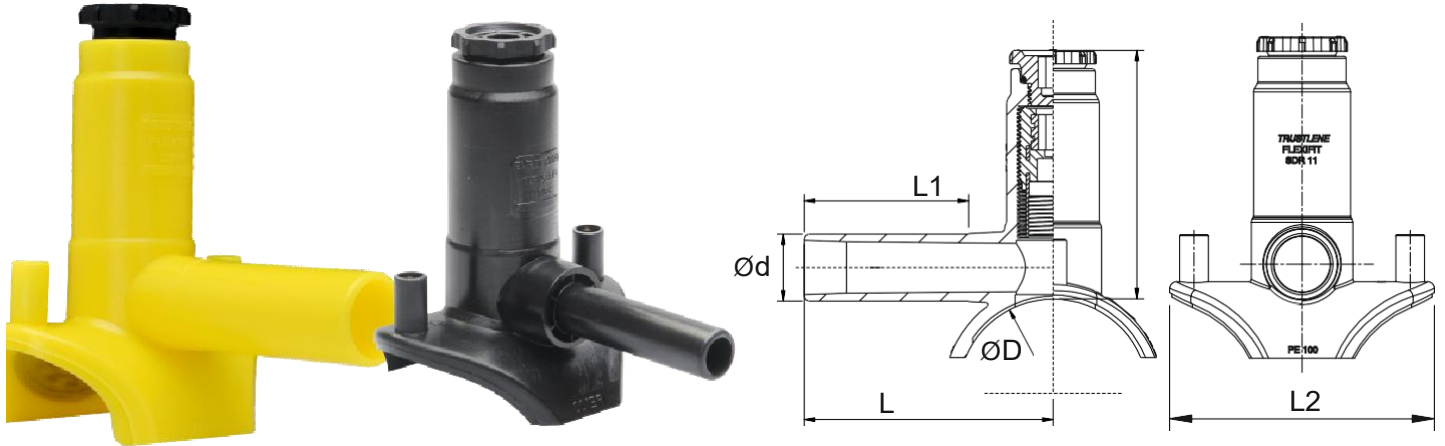

Kimplas Electrofusion Flexi-Fit Tapping Tees are manufactured in PE 80 (yellow) and PE 80 BK material and are of SDR 11 rating (PN 16). For exact recommendations on compatibility, for welding with SDR 9 through SDR 21 or PN 6 through PN 16 pipe, refer Kimplas Technical Specifications Manual. Kimplas Electrofusion TTs are suitable for tapping from PE 80 and PE 100 pipes, both in straight as well as in coil form.

### SPECIFICATION TABLE

d	Product Code	SP	Weight (gm)	H(mm)	L (mm)	L1(mm)	L2(mm)	FT	CT
63-75x20	FFT63T75X20BK8B	20	241	119	118	76	120	70	4
63-75x25	FFT63T75X25BK8B	20	241	119	118	76	120	70	4
63-75x32	FFT63T75X32BK8B	20	241	119	118	76	120	70	4
90-140x20	FFT90T140X20BK8B	20	266	119	118	76	120	70	4
90-140x25	FFT90T140X25BK8B	20	266	119	118	76	120	70	4
90-140x32	FFT90T140X32BK8B	20	266	119	118	76	120	70	4
160-225x20	FFT160T225X20B8B	20	315	136	130	76	120	80	4
160-225x25	FFT160T225X25B8B	20	315	136	130	76	120	80	4
160-225x32	FFT160T225X32B8B	20	292	136	130	76	120	80	4
250-315x20	FFT250T315X20B8B	20	315	136	130	76	120	80	4
250-315x25	FFT250T315X25B8B	20	315	136	130	76	120	80	4
250-315x32	FFT250T315X32B8B	20	292	136	130	76	120	80	4

BK8B - PE 80 Black - 4mm Pin  
YEA - PE 80 Yellow - 4.7mm Pin

SP=Standard Pack Quantity, FT=Fusion Time in Seconds, CT=Cooling Time in Minutes, SP and Weight are given for reference only

Note: Every effort has been made to ensure the information in this brochure is correct at the date of issue. Kimplas operates a policy of continual product improvement and range extension, hence reserves the right to modify product specifications, without prior information, in line with market requirements.

## STANDARDS

- PE Pipe Compatibility : IS:14885, ISO:4437, EN:1555-2, EN: 12201-2, ISO:4427, IS: 4984, DIN:8074.
- Complies with EN1555- Part 3 for Gas, EN12201- Part 3 for Water. AS/NZS 4129 for Gas & Water GIS-PL2-Part 4 for Gas

## COMMON APPLICATIONS

- Tapping from Charged or Uncharged network for House Service Connections.
- Branch connections.
- Tapping connections in areas difficult to access in narrow trenches.

## INSTALLATION

Joint preparation must be done as specified in the installation instructions. Pipe outside surface must be scraped to remove oxidized layer. Before fusing, scraped pipe-surface and matt area of the fittings must be cleaned to remove dirt and contamination. Complete Installation Manual may be downloaded.

## ADVANTAGES

- Standard Operating Voltage -40V.
- Same fusion time for various SDR and PN rated pipes.
- Auto temperature compensation for ambient conditions of -5°C to + 40°C.
- Top load takes care of saddle base radius matching (alignment) with pipe OD even in case of ovality of coiled pipes.
- Optimal fusion and cold zone for a sturdy joint.
- Pop-Up fusion indicators to indicate fusion process performance.
- Integral composite cutter. Once TT fused, cutter cannot be taken out.
- Cutter retains the pipe coupon positively, never allows it slip into pipe.
- Permanent Batch Indicator, Fusion Time, Cooling Time, Raw Material Grade and SDR marking.
- Each fitting individually packed to protect against contamination and oxidation.
- Each fitting with water-proof bar code to automatically feed fusion data to the Control-box for fusion process.

## Contact Us

### Kimplas Piping Systems Private Limited

B-20, MIDC , Ambad, Nashik- 422010 | India | [www.kimplaspiping.net](http://www.kimplaspiping.net)

