

ELECTROFUSION I.C. END CAP

For Gas/Water-SDR 11 (ISO S5)

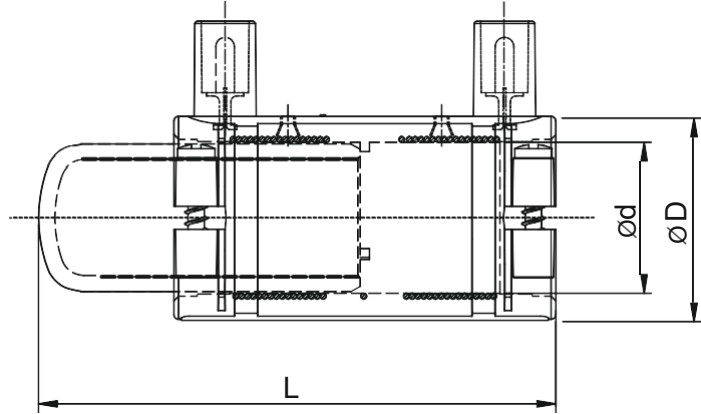

Kimplas Electrofusion End cap are manufactured in PE 100 Black material and are of SDR 11 rating (PN 16). For exact recommendations on compatibility, for welding with SDR 9 through SDR 21 or PN 6 through PN 16 pipe, refer Kimplas Technical Specifications Manual. Kimplas Electrofusion fittings are suitable for permanently connecting MDPE 80 and PE 100 pipes, both in straight form as well as in coil form.

SPECIFICATION TABLE

d	Product Code	SP	Weight (gm)	D (mm)	L (mm)	FT	CT
20	ECSC20BKD	140	53	31	103	22	4
25	ECSC25BKD	120	78	36	105	28	4
32	ECSC32BKD	85	95	44	109	42	4
40	ECSC40BKD	40	131	53	119	52	7
50	ECSC50BKD	36	202	65	142	55	7
63	ECSC63BKD	24	326	81	158	70	7

BKD - PE 100 Black - 4mm Pin

SP=Standard Pack Quantity, FT=Fusion Time in Seconds, CT=Cooling Time in Minutes, SP and Weight are given for reference only

Note: Every effort has been made to ensure the information in this brochure is correct at the date of issue. Kimplas operates a policy of continual product improvement and range extension, hence reserves the right to modify product specifications, without prior information, in line with market requirements.

STANDARDS

- EF end cap consisting of standard EF coupler and spigot end cap Complies with EN1555- Part 3 for Gas, EN12201- Part 3 for Water. AS/NZS 4129 for Gas & Water, GIS-PL2-Part 4 for Gas
- PE pipe compatibility- IS: 14885, EN 1555-2, IS: 4984, EN 12201-2, ISO: 4437 DIN: 8074, ISO: 4427-2.

COMMON APPLICATIONS

- Closing ends of pipe permanently on mains and distribution pipes in a distribution network.
- Closing spigot end fittings.

INSTALLATION

Joint preparation must be done as specified in the installation instructions. Pipe outside surface must be scraped to remove oxidised layer. Before fusing, pipe ends and spigot end of the fittings must be cleaned to remove dirt and Contamination. Complete Installation Manual may be downloaded.

ADVANTAGES

- Standard operating voltage - 40 V.
- Provided with Screws for quick connection of pipes. No need of external clamps.
- Fitting with integral clamping for holding and exact fitment of fitting with pipe.
- More connections with less effort. Save time on site.
- Brings down inventory of tools and associated costs.
- Clearance Fit for ease of installation and removable centre stops for easy repairs.
- Same fusion time for various SDR rated pipes.
- Optimal fusion and cold zone for a strong and sturdy joint.
- Permanent Batch Indicator, Raw Material Type and SDR marking.
- Each fitting individually packed in PE bag to protect against contamination and oxidation.

Contact Us

Kimplas Piping Systems Private Limited

B-20, MIDC , Ambad, Nashik- 422010 | India | www.kimplaspiping.net

